

Power Input

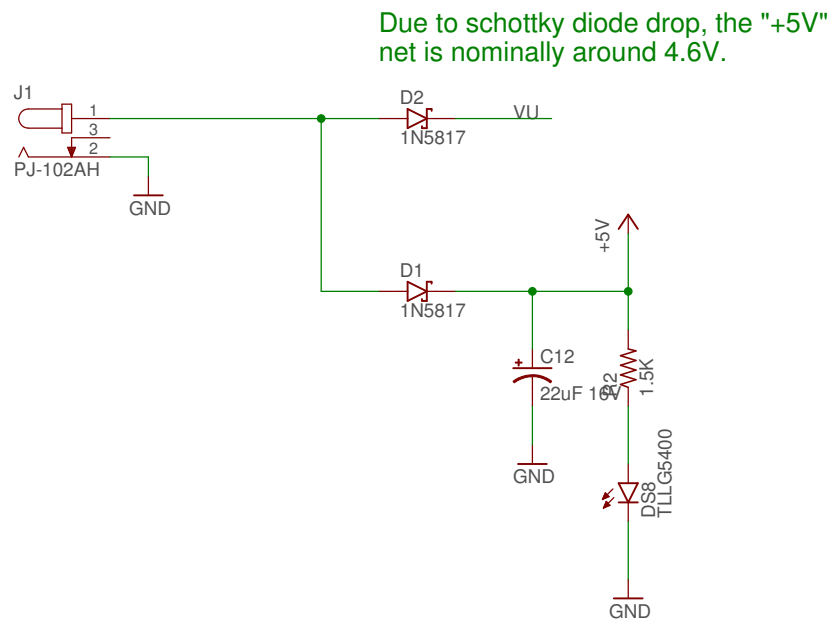

Configuration Switches

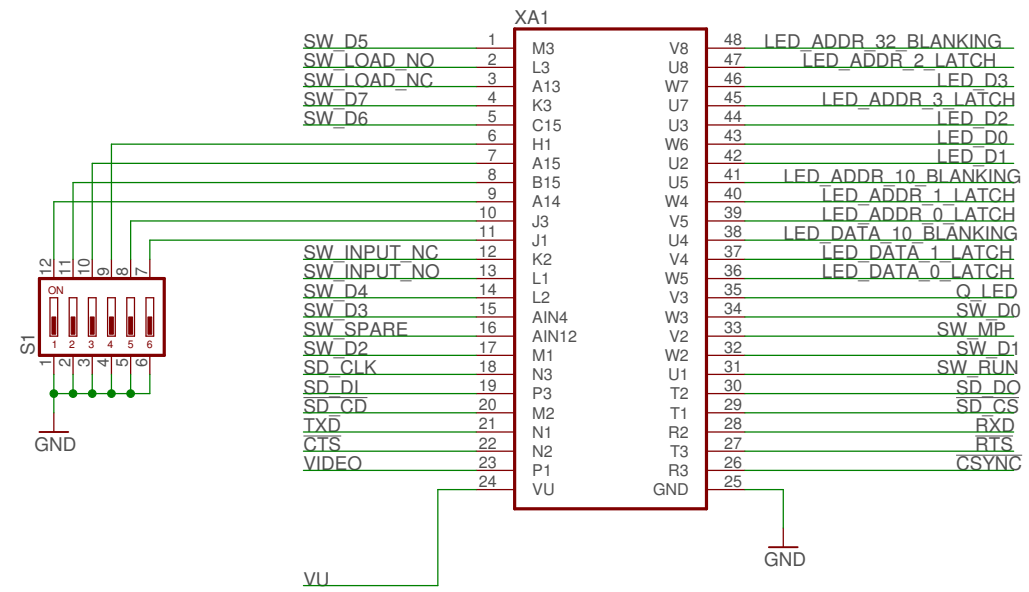

FPGA Module

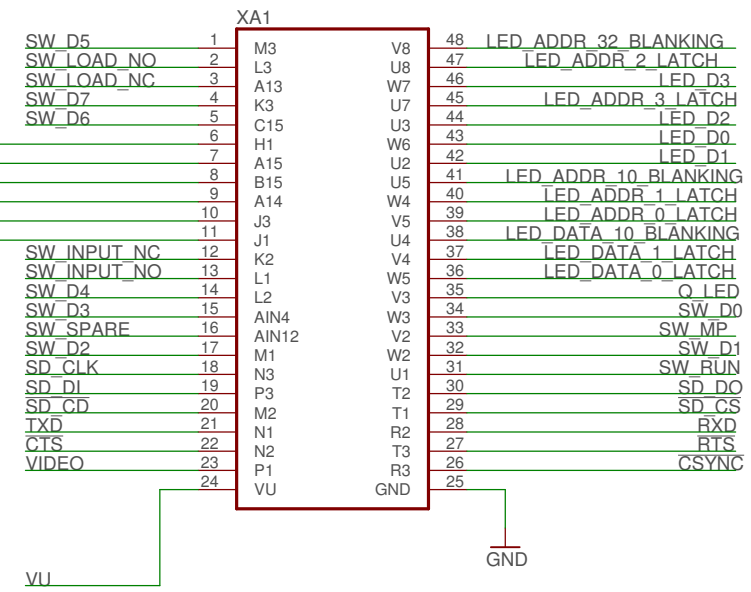

Front Panel Connector

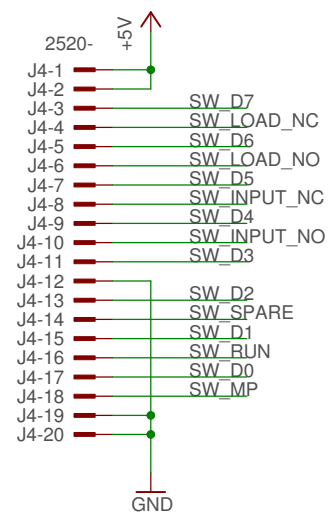

MicroSD

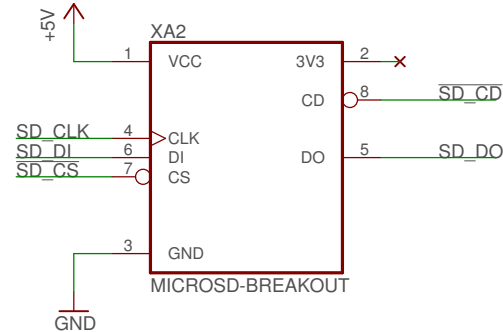

Composite Video

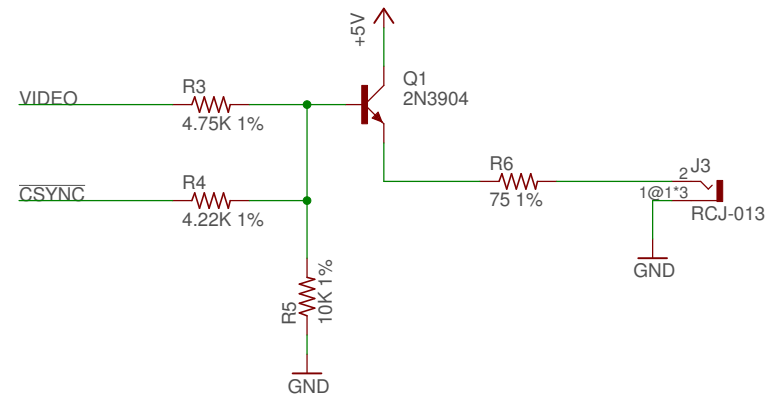

TIA-232-F Interface

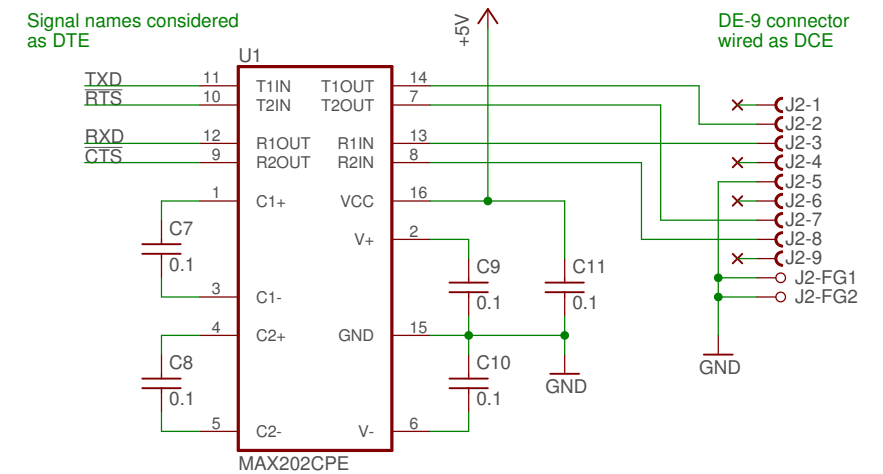

ELF-CMOD-A7
 Power, FPGA module, I/O
 Copyright 2017 Eric Smith
 <spacewar@gmail.com>
 Drawing Number:
 File: elf-cmod-a7 REU: 0
 Date: 10/16/17 11:42 PM Sheet: 1/2

Q_LED

LED_ADDR_1_LATCH
LED_ADDR_0_LATCH
LED_ADDR_10_BLANKING

LED_ADDR_3_LATCH
LED_ADDR_2_LATCH
LED_ADDR_32_BLANKING

LED_DATA_1_LATCH
LED_DATA_0_LATCH
LED_DATA_10_BLANKING

LED_D[0..7]

Footprints of DS1H..DS6H, HP 5082-7340,
are superimposed with footprints of
DS1T..DS6T, TI TIL311.
Use of HP and TI displays are
mutually exclusive.

Place capacitors on this schematic page
as close as practical to the HP display
(DSnH) Vcc and GND pins.

DATA display

ADDR HIGH display

ADDR LOW display

HP LED display option

HP LED display option

HP LED display option

Place C106 near
U6H Vcc and GND pins.

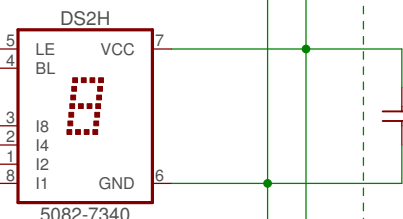
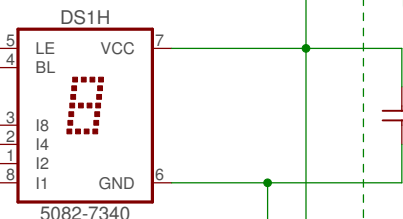

TI LED display option

TI LED display option

TI LED display option

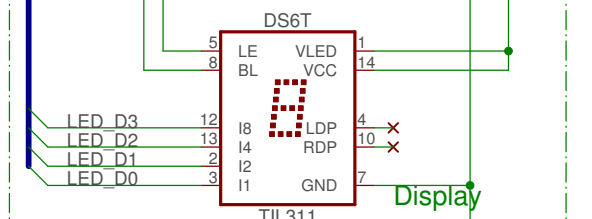
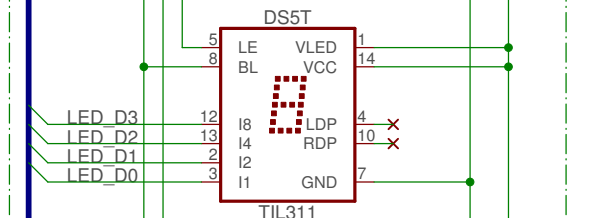
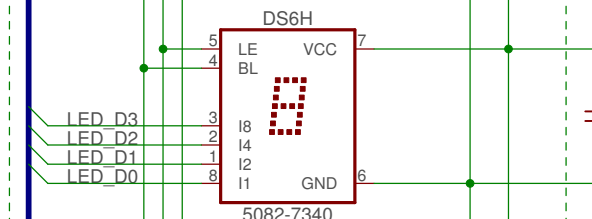
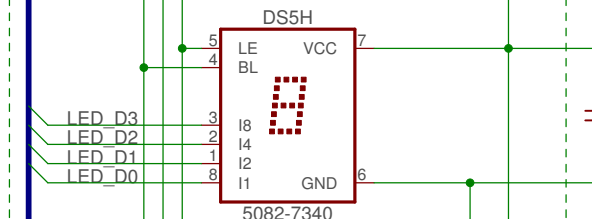
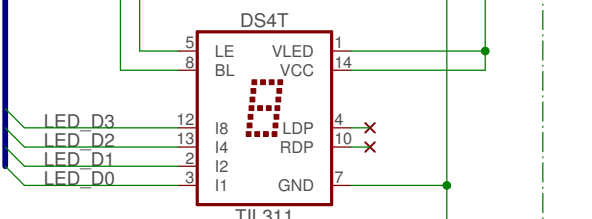
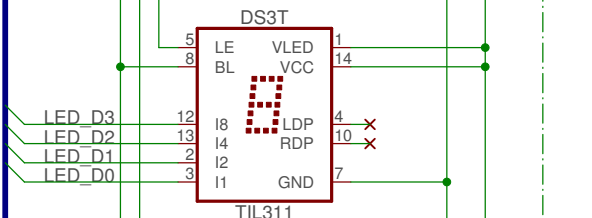
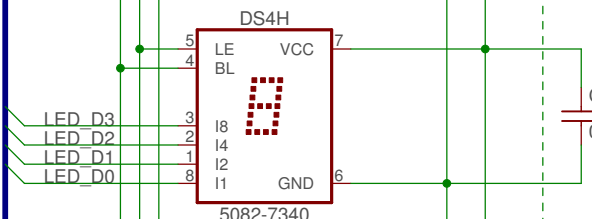
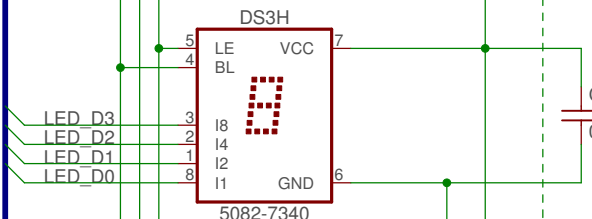
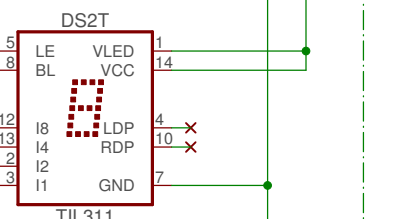
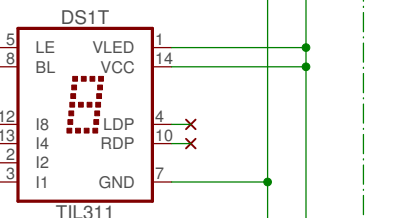

ELF-CMOD-A7

Display

Copyright 2017 Eric Smith

<spacewar@gmail.com>

Drawing Number:

File: elf-cmod-a7

REV:

Date: 10/16/17 11:42 PM Sheet: 2/2